



Metcalfe Medium Duty Vertical Slicer

NSV350HD

Installation & Operating Instructions



Index

Your Slicer	2
Technical Data	3
Optional Extras	4
Installation	
Suitable Products for Slicing	5
Unpacking	5
Installation	5
Operation	6
Cleaning Instructions	
Disassembly	7-8
Cleaning	9
Reassembly after Cleaning	10
Sharpening the Knife	11
Lubricating your Slicer	12
Slicer Safety Tips	12
Troubleshooting	13
Maintenance	13
Spare Parts & Service	14
Product Information	14
Warranty	15

Your Slicer

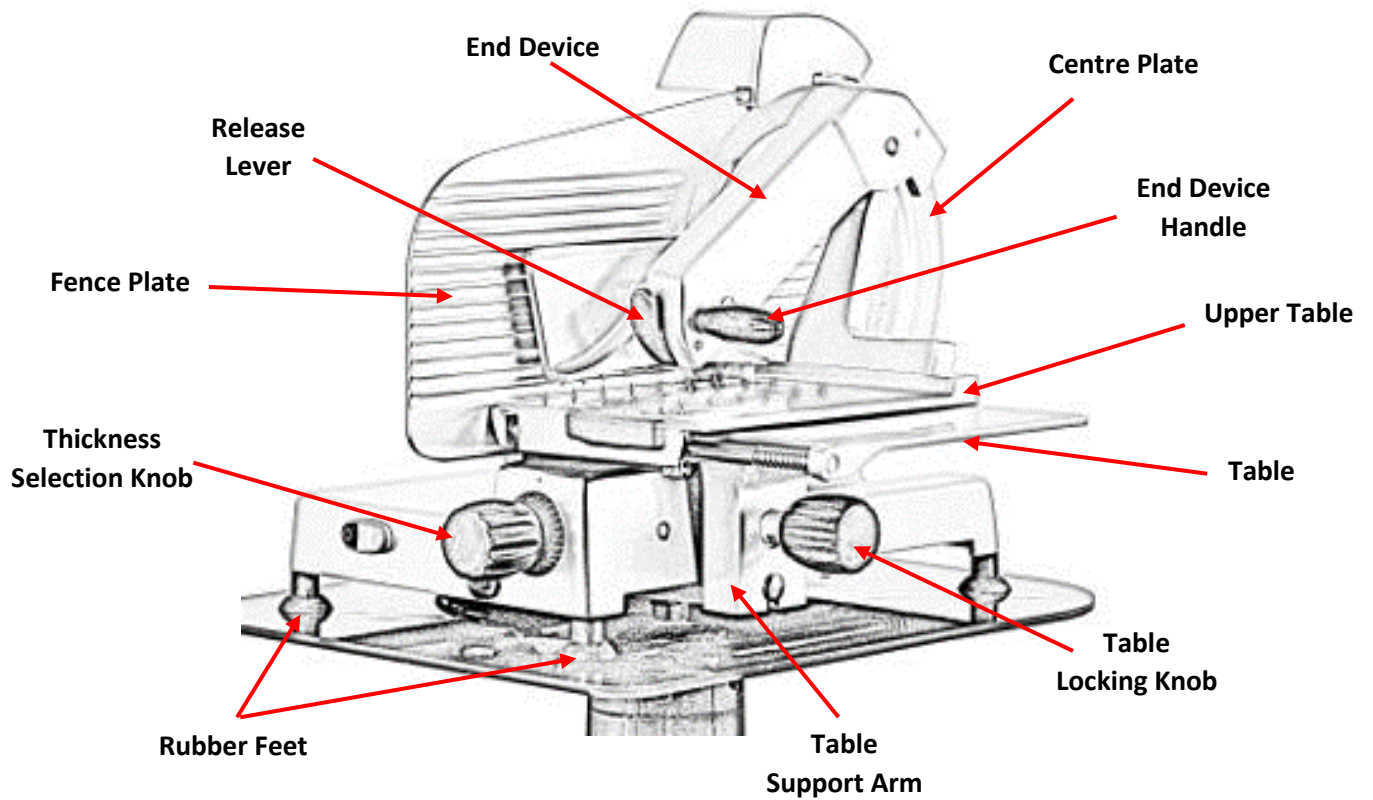
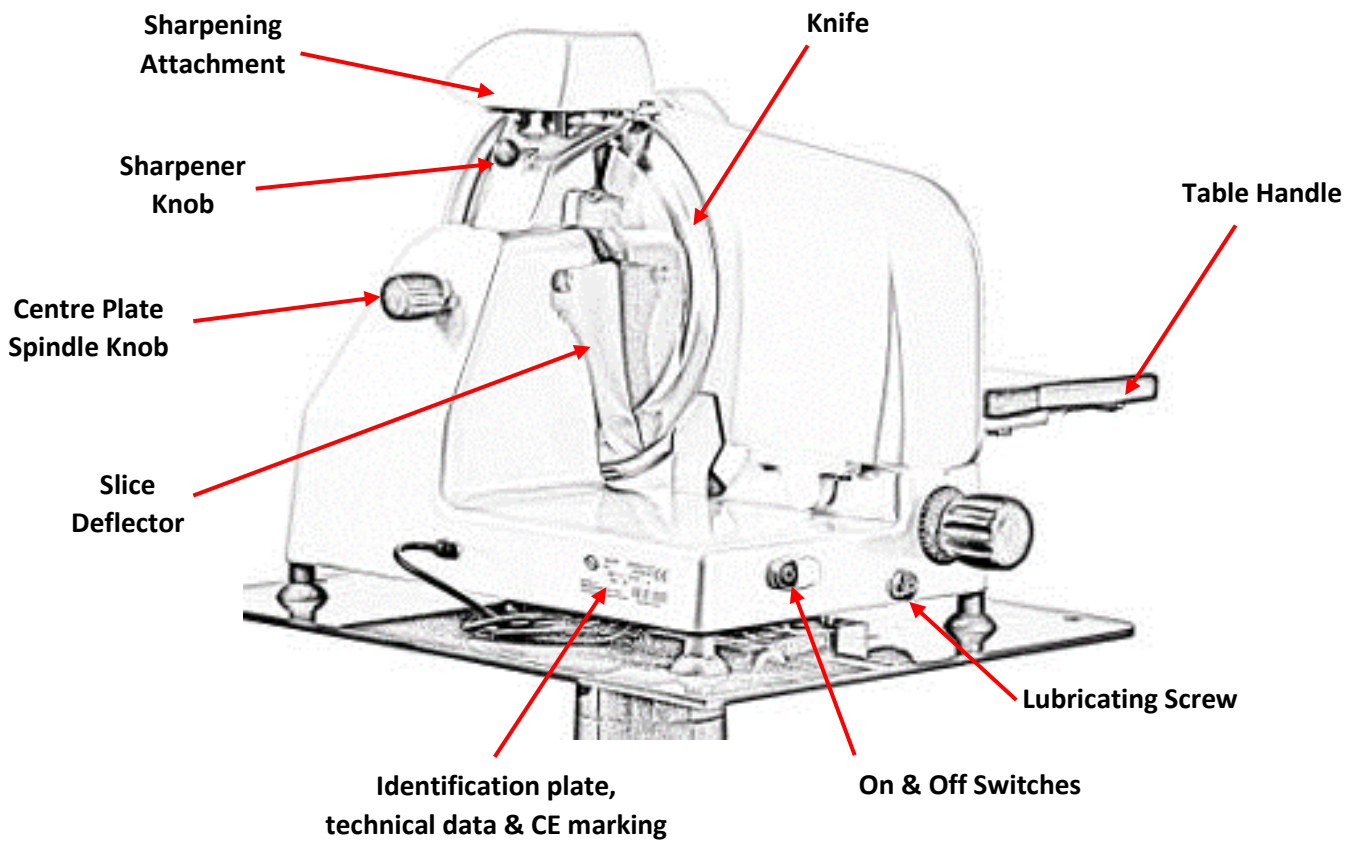

(Image may differ to actual slicer)

Metcalfe NSV350HD Heavy Duty 350mm Vertical Slicer

Features

- Designed for handling larger volumes than the medium duty range. Recommended for delis, restaurants, supermarkets and canteens
- Large double sliding tables with lockable, clamp grips to secure product to the slicing table to aid precision slicing
- Ideal slicers for heavy cured meats including bacon, Parma ham, Serrano ham, Bresaola and salami
- Hollow ground chromed carbon steel blade
- Powerful twin poly 'V' belt driven transmission gives a smooth cutting action and silent running
- Easy belt adjustment
- Easy set thickness control allows for precision slicing
- Carriage slides on ball bearings for smooth carriage glide
- Made from high polished, anodised food grade aluminium for durability and hygiene
- Large base to ensure slicer has a large capacity to cope with large products
- Ergonomic design with smooth rounded edges to allow for fast and easy cleaning and improved levels of hygiene
- Fully interlocked and safe guarded for full compliance of CE legislation. This ensures all-round blade protection for ultimate user safety during cleaning
- Built-in self-aligning sharpening and de-burring unit
- Table/carriage, blade cover, blade and sharpening unit are detachable for easy, safe cleaning
- CE Approved

Technical Specifications

Model	Blade (mm) / (Inch)	Phase (Ø)	Motor (Volt)	Frequency (Hz)	Current (Amp)	Power (kW)
NSV350HD	350 / 14	1	220	50	1.68	0.370

Capacity

Model	Cutting Capacity (mm)		Carriage Movement (mm)	Max Slice Thickness (mm)
NSV350HD	● 265	□ 265 x 310	365	16

Dimensions | Shipping Information

Model	Overall Dimensions D x W x H (mm)	Net Weight (kg)	Packed Dimensions D x W x H (mm)	Packed Weight (kg)	Volume (m3)
NSV350HD	710 x 900 x 585	47	720 x 840 x 760	54	0.46

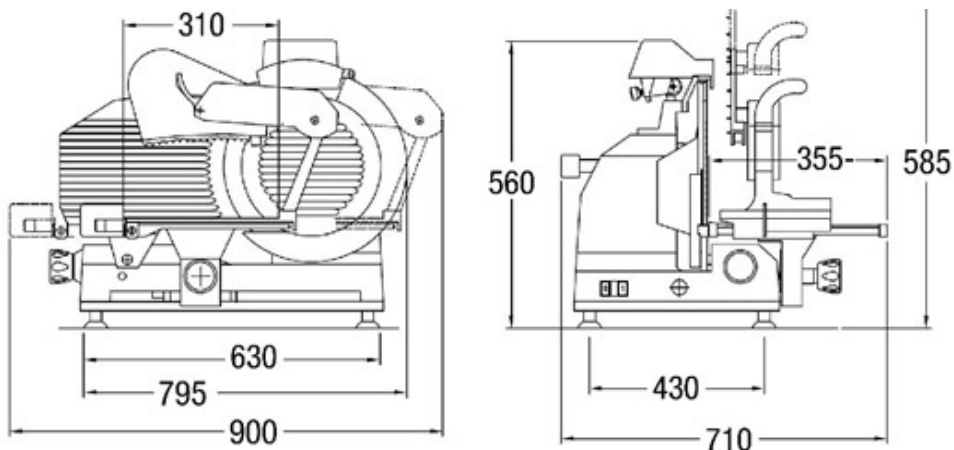

Optional Extras



Teflon Coated Parts, 20% increased in gliding property



Stainless Steel Knife Remover



Aluminium Knobs Kit



Special Stainless Steel Handgrip

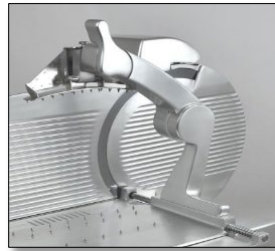

Special Arm (protected)



Serrated Blade



Plastic Cover

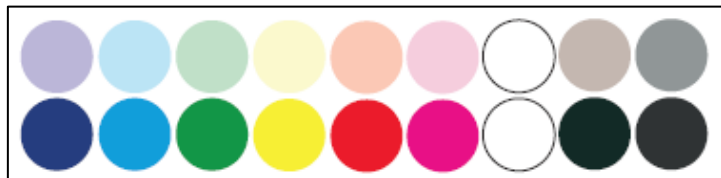

Painting Customisation

For more information and prices please contact the sales department (see page 14).

Installation

Suitable Products for Slicing

The following are products that can be sliced:

- All types of cold cuts (cooked, raw, smoked)
- Boneless meat (cooked or raw at a temperature of no lower than +3°C)
- Cured meats (Bresaola, Parma Ham, Serrano Ham & Salami etc)
- Bread and cheese (those that can be sliced, such as Gruyere, Fontina, etc.)

The following are products that cannot be sliced because they could cause damage to the machine:

- Frozen food (Only with Serrated Blade see page 4)
- Deep-frozen food
- Food with bones (meat & fish)
- Vegetables
- Any other products not meant for consumption

Unpacking

Unpack the slicer immediately after receipt. Please inspect the slicer to ensure there is no damage and that all parts are included i.e. Knobs, Feet and Knife Removing Tool. If the machine is found to be damaged, keep all the packaging material and contact us or contact your source of the equipment immediately.

You should receive with your slicer:	1 x Metcalfe Tasteless Oil	1 x Flat Head Screwdriver
	1 x Instruction Manual	1 x Knife Removing Tool

If any of the above items were not received with your slicer, please refer to page 14 for contact details and inform us immediately for replacements.

Please ensure that you complete the product information section on page 14.

Installation

1. Read this manual thoroughly before installation and operation. DO NOT proceed with any installation nor operation if you have any questions or do not understand anything in this manual. Please see Metcalfe Catering Equipment Ltd contact details on page 14 to resolve any queries you may have.
2. Make sure to clean and sanitise the entire slicer before use (see Cleaning Instructions on Pages 7-10).
3. Select a location for the slicer that is level, smooth, solid, dry, non-skid and suitable to withstand the weight of the slicer plus the food to be sliced.

Operation

1. Ensure the slicer is turned off and that the thickness selection knob is set to "0".
2. Pull back the carriage completely (towards the operator) to the loading position.

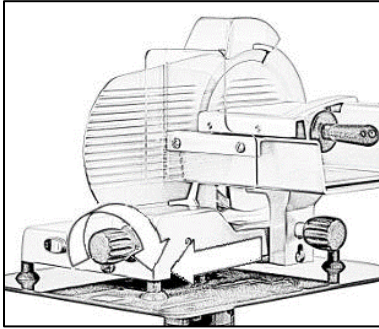

3. Lift the end device up, using the release lever, into the rest position.

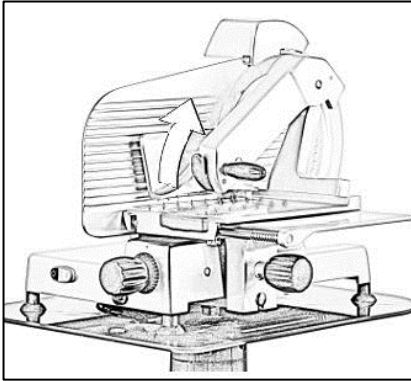

4. Place product onto the table, block it with the end device by lowering it onto the product and pressing down slightly.

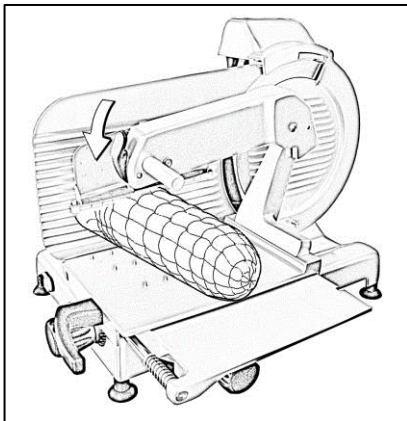

5. Rotate the thickness selection knob anti-clockwise to the desired setting.
6. Turn the slicer on by pushing the start button. The power indicator light, which is located between the on/off switch, will illuminate.

DO NOT hold the food product with your hand. Never put your hand on or around the table while the slicer is on. The end device handle and table handle are the only parts of the slicer you should touch while slicing.

7. Grip the end device handle and table handle and manually push the carriage back and forth applying pressure both parallel (alternating movement of the food) and perpendicular (advancement of food) to the blade.

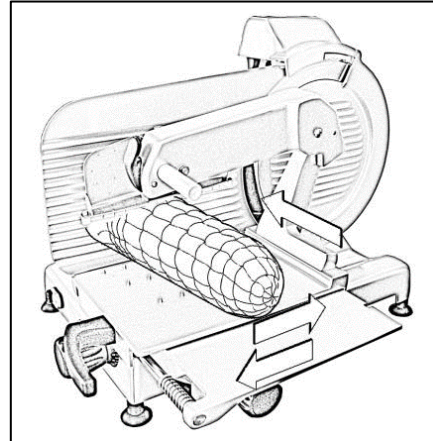

DO NOT catch slices with your hands, let slices drop onto the receiving area.

If a product needs to be adjusted during slicing, first turn the slicer off and then pull the table all the way towards you.

8. After the last slice stroke, pull the carriage all the way towards you. Turn the slicer off by pressing the stop button, the power indicator light will go out. Turn the thickness selection knob clockwise until it stops to close the slicer table.
9. You can now unload the product from the table.

Cleaning Instructions

Daily cleaning should be considered mandatory for all equipment used in the preparation of food. When using a meat slicer and with the possibility of cross contamination, these units should be cleaned before slicing each new product. Once your slicer makes contact with any food product, the entire slicer, including removable parts, must be thoroughly cleaned. This process is to be repeated at the end of each working day. If the machine has not been used for a while it must be cleaned before use.

In order to ensure the slicer is cleaned properly and to avoid damage, the instructions below should be followed.

Disassembly

Turn slicer off and unplug from mains.

Turn the thickness selection knob clockwise past "0" until it stops so the fence plate covers the blade.

Disassembling the table

- With the thickness selection knob on "0" pull back the carriage all the way to the left.
- Whilst supporting the table, turn the table locking knob anti-clockwise all the way until you hear the click of the pin locking into place.

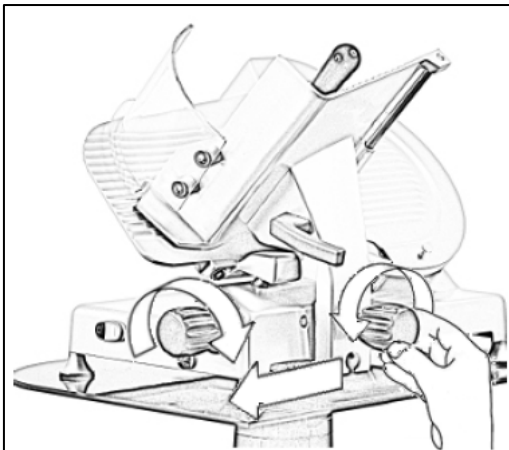

- Once fully unscrewed lift the whole of the table and carriage from the machine.

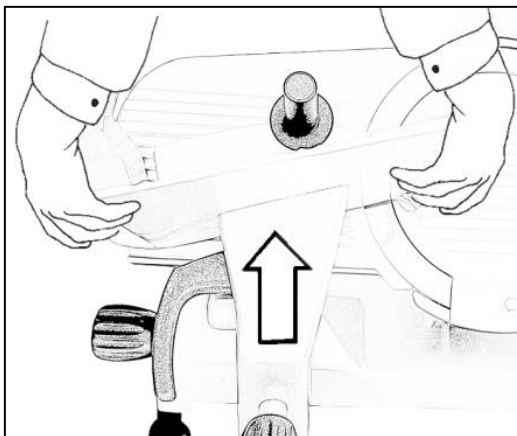

Disassembling the centre plate (blade cover)

- Unscrew the centre plate spindle knob (anti-clockwise) and remove from the rear of the machine.

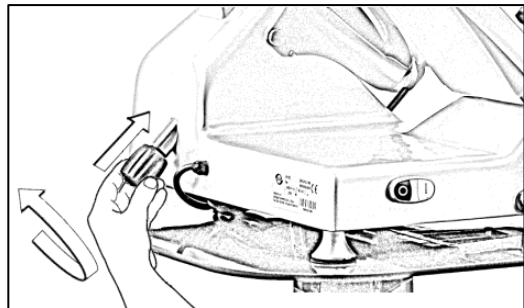

- Lift the centre plate using the knob located at the bottom.

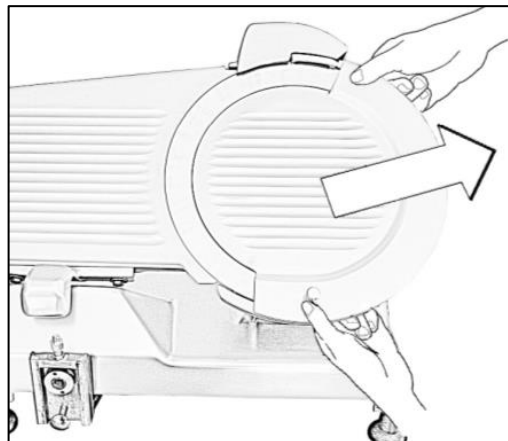

Disassembling the knife

- Fit the knife removing tool (supplied with machine) over the knife and secure it by tightening the two knobs.
- Once the knife removing tool is secure loosen the four screws securing the knife to the pulley.
- Pull off the knife removing tool with the knife **ALWAYS REMOVE HOLDING THE KNOBS.**

Disassembling the slice deflector

- Remove the slice deflector by sliding it to the left

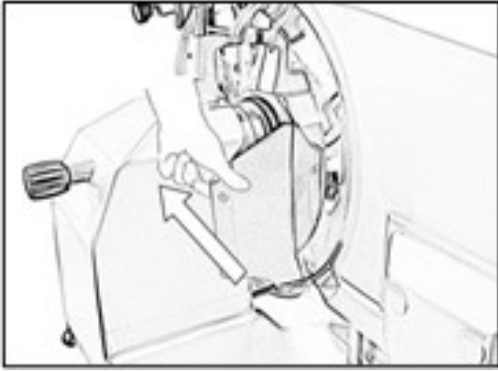

Disassembling the sharpener

- Lift the sharpener cover.

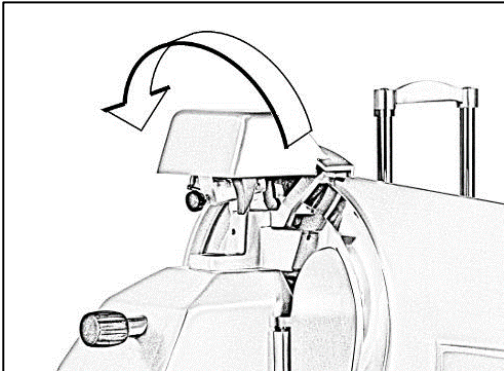

- Loosen the side knob of the sharpener block and remove it.

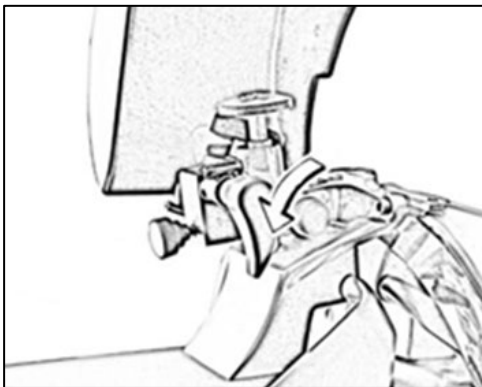

- Then remove whole sharpener.

Cleaning

- Only use warm water and a mild detergent to clean all parts, using a soft, spongy cloth and nylon brush.
- Do not use other metal products to scrape or remove stubborn deposits of sliced product.
- Never leave any leftover product on the slicer (Clean at least once a day).
- DO NOT clean the unit, or any parts of the unit in a dishwasher.
- Rinse all parts after cleaning with clean water and dry with a soft cloth.
- Do not use abrasive cleaners, acids, steel wool or high-pressure water jets which might damage the machine.

Cleaning the knife

- To clean the knife whilst still on the machine, use a damp cloth on the blade and move it slowly from the centre outwards to the edge.

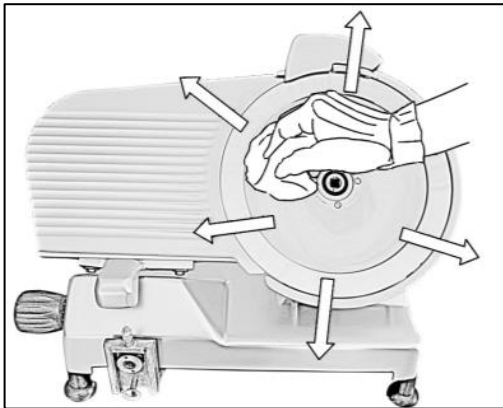

- Dry the knife in the same way

Cleaning the back knife guard

- To clean the back knife guard, pass a damp cloth between the blade and the back knife guard.

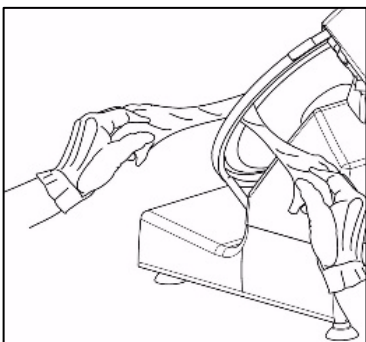

Cleaning the sliding plate and upper table

- Move the upper table as shown below

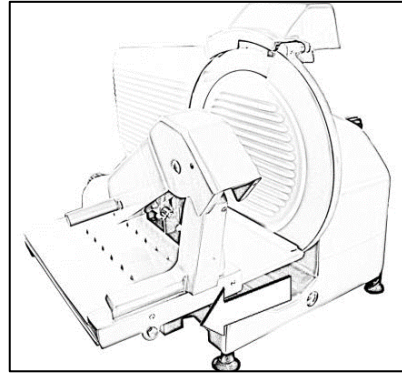

- Raise the sliding upper table and clean with a damp cloth or a sponge.

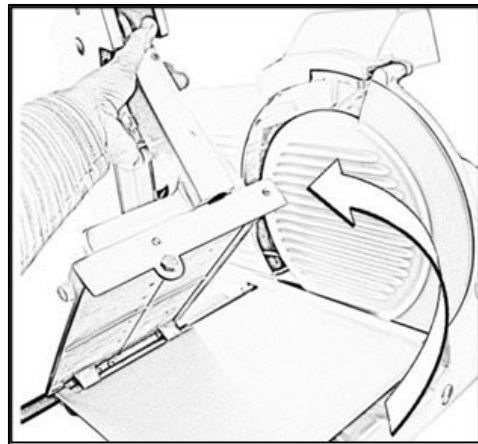

Cleaning the machine body

- Clean the machine body with a damp cloth or sponge, rinsing frequently with hot water. Dry carefully.

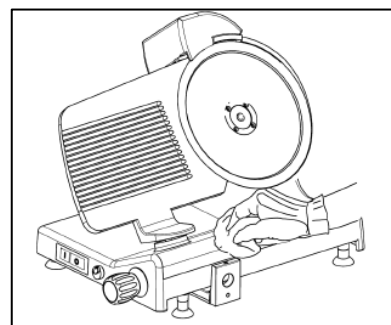

Reassembly After Cleaning

Reassembling the sharpener

- Replace the sharpener by inserting the locking tie rod in its proper place (1.)
- Turn the side knob of the sharpener block all the way (2).

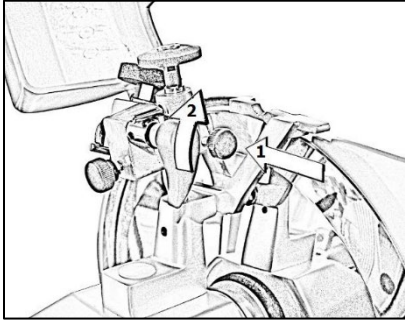

- Close the sharpener cover.

Reassembling the slice deflector

- Insert the slice deflector over pins and slide back into position.

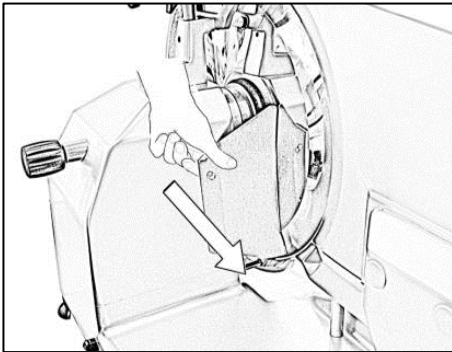

Reassembling the centre plate

- Insert the centre plate over the knife and ensure that the flutes are flush with the flutes on the fence plate.

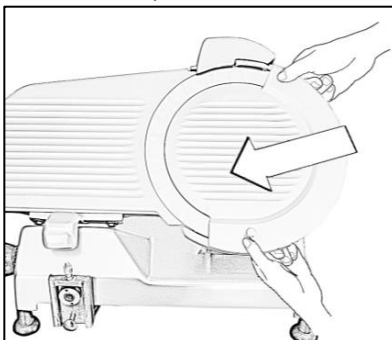

- Insert the centre plate spindle completely and rotate clockwise to secure.

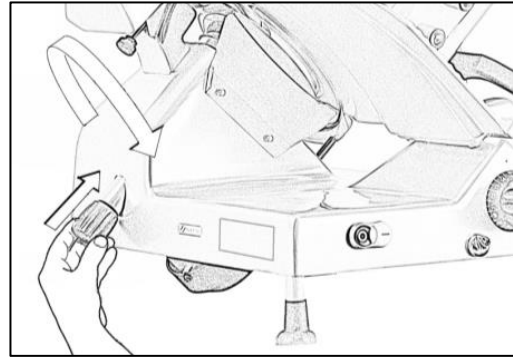

Reassembling the table

- Insert the table on the carriage

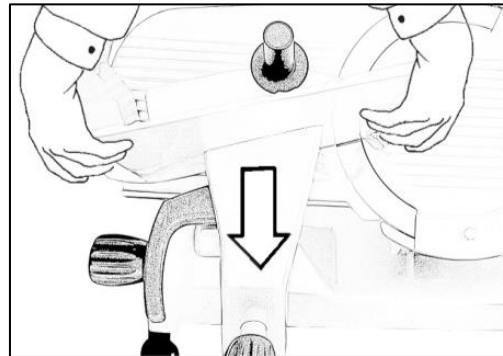

- Tighten the table locking knob

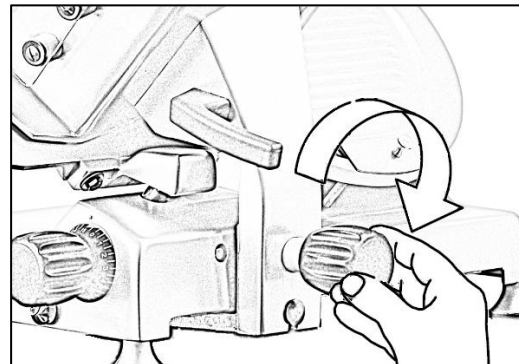

- Check that the table moves freely from left to right
- Check that the thickness selection knob works correctly

Sharpening the Knife

When and How Often to Sharpen the Knife

- Symptoms of a dull knife are excess waste on the unsliced portion.
- The blade needs to be sharpened periodically to provide consistent slices and maximum food product.
- Sharpening the blade lightly every few days is more effective than heavy sharpening at less frequent intervals.
- **WARNING:** The blade can be sharpened up until the distance between the cutting edge of the blade and the inside border of the blade guard ring is no more than 6 mm, corresponding to a decrease of about 10 mm of the size of the original diameter. Once this value has been reached, it is **NECESSARY TO REPLACE THE BLADE.**

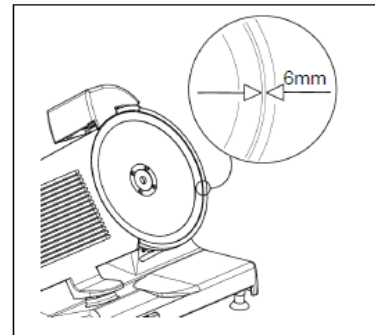

Sharpening the Knife

NOTE: Before starting check that the grindstones have been cleaned.

- Turn the slicer off and rotate the thickness selection knob clockwise until it stops and the slicer fence plate covers the knife.
- Pull back the carriage all the way to the left.

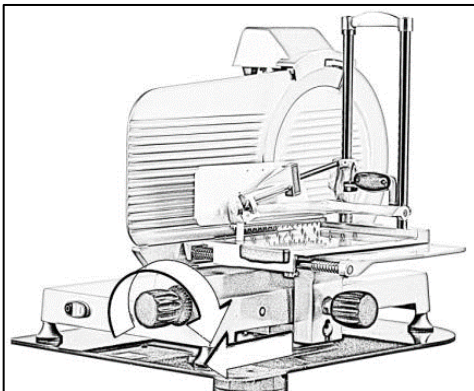

- Clean and dry both sides of the blade before sharpening. Please refer to cleaning instructions.
- Lift the sharpener cover.

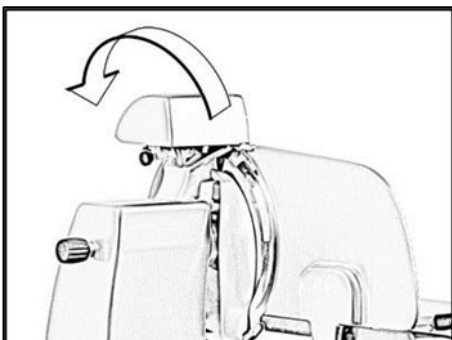

- Pull the knob (1) to release the sharpener and flip it over so that the sharpener assembly is closer to the blade (2).
- The sharpener is now hooked in the correct position for sharpening.

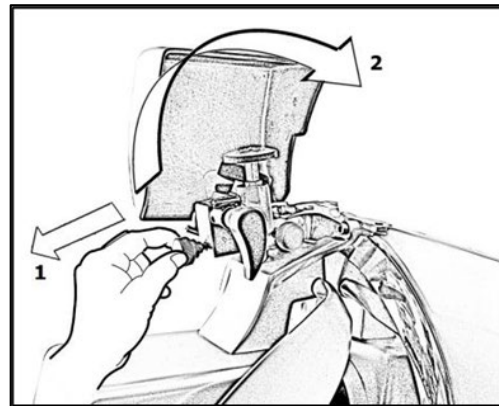

- Plug in and select the start button on the slicer.
- Push the sharpening stone lever downwards and keep it pressed for 10 seconds
- Then deburr by pressing the lever further down for 2-3 seconds (more could damage the blade edge).

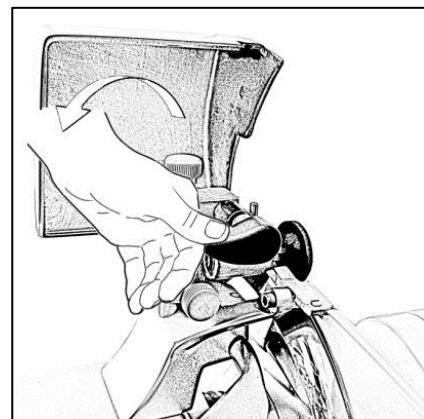

TURN SLICER OFF before inspecting.

- Return the sharpener to the original position using the blocking knob and close the cover.
- Clean the entire slicer.

Lubricating Your Slicer

NOTE: Use only the tasteless oil provided or white Vaseline oil. **Do not** use vegetable oils!

Lubricating the bottom runner guide bars (weekly)

- Move the carriage as close as possible to the operator
- Insert the oiler in the special hole/lubricating screw
- Squeeze the oiler so that a small amount of oil goes into the hole
- Remove the oiler and slide the carriage 3 to 4 times.

NB: Not all machines are equipped with a lubricating screw. If so, lift the machine and lubricate the carriage bar directly.

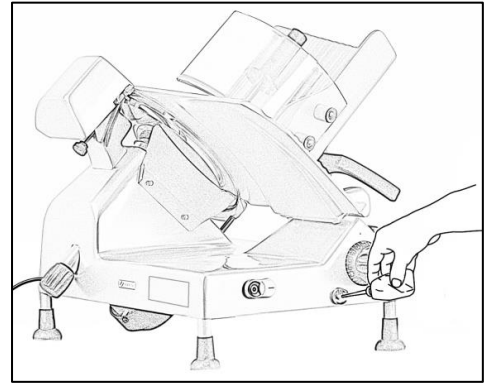

Lubricating the transversal guide rods of the table and end device (weekly)

- Put a small amount of oil on the rod and slide the group 3 to 4 times.
- Clean as necessary removing any excess oil.

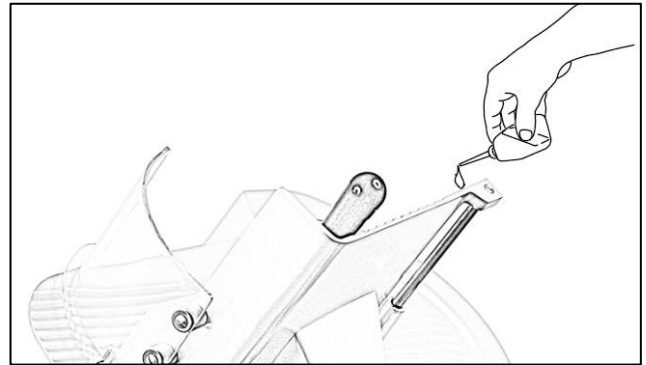

Slicer Safety Tips

To avoid serious personal injury:

- **NEVER** touch the slicer without training and authorisation from your supervisor or if you are under the age of 18. Read this instruction manual first.
- **ONLY** install the slicer on a level, non-skid surface that is non-flammable and located in a clean, well-lit work area and away from children and visitors.
- **NEVER HOLD THE FOOD PRODUCT WHILE SLICING.** Hold only the end device handle while slicing.
- **BEFORE CLEANING, SHARPENING, SERVICING, OR REMOVING ANY PARTS** always turn the slicer off, turn the thickness selection knob clockwise until it stops and unplug power cable.
- **NEVER** touch rotating knife.
- **ALWAYS** keep hands clear of all moving parts.
- **ALWAYS** turn slicer off, turn the slicer thickness selection knob clockwise until it stops.
- **NEVER** place the power cord over the unit.

Troubleshooting

If the slicer is not working correctly please check the list below before contacting an engineer or Metcalfe Catering Equipment Ltd.

Problem	Possible Causes	Action Required
Pressing the start button does not start the machine.	No electricity.	Check that the plug is correctly inserted.
Pressing the start button the machine starts but the working light does not come on.	Light is defective.	Do not use the machine if the light does not work. Contact Service for assistance.
The machine starts but the motor heats up too much and gives off a bad odour.	Defective motor.	Do not use the machine. Contact Service for assistance.
The machine vibrates.	Defective transmission.	Contact Service for assistance.
Excessive resistance in cutting the product.	The blade is not sharp.	Sharpen the blade.
The blade slows or stops under stress.	Loose belt.	Contact Service for assistance.
Sharpening is no longer regular.	Grindstones are excessively dirty.	Clean the grindstones.
	Grindstones are worn out.	Replace the grindstones. Contact Service for assistance.
The sliced product is frayed and irregular.	The blade is not sharp.	Sharpen the blade.
	The blade is excessively used.	Replace the blade. Contact Service for assistance.
The machine does not stop when the button is pressed.	Control circuit is defective.	Pull out the plug to stop the machine immediately and contact Service for assistance.

If the problems persist and the assigned solution does not remedy the problem, please call our Service Department.

Maintenance

Only the maintenance listed below is recommended for the operator to carry out, all other maintenance should be done by an approved engineer:

- Knife sharpening.
- Lubrication of the bottom runner guide bars and end device (weekly).
- Check the condition of the electrical cable and the cable gland on the base of the machine (periodically).
- Replace Knife.
- Replacing the sharpening stone.

Maintenance to be carried out by engineer only:

- Replacing the components of the electrical system under the base.
- Repairing the structural parts, repairing and/or replacing components under the base.

Spare Parts and Service

For more information on Metcalfe spare parts, accessories and service support, including breakdown drawings and parts lists please contact us on the details below.

Please always quote the Serial Number of the machine. This can be found on the serial number plate which is located on the right-hand side of the machine's base.

Metcalfe Sales & Spares Department sales@metcalfecatering.com
Metcalfe Service Department service@metcalfecatering.com
Metcalfe Website www.metcalfecatering.com
Metcalfe Telephone Number 01766 830 456



Additional copies of this instruction manual can be obtained by either visiting our website or contacting the sales department.

Product Information

Please complete the below details and keep in a safe place. Ensure that you complete the Model No & Serial No sections for future reference when enquiring about spare parts and technical assistance.

Company Name: _____

Company Address: _____

Model No: _____ Serial No: _____ Date of Purchase: _____

Name of Dealer: _____

Please retain this information for your records

Metcalfe Warranty

All Metcalfe products are guaranteed against defects in material and workmanship for a period of one year from date of invoice, except where specifically noted.

The Company's obligation under this warranty is limited to repairing or replacing, without charge, any part or parts found to be defective under normal use, in accordance with the specified operations manual and capacity ratings.

On all return to factory warranty items, it is the responsibility of the purchaser to return the entire unit to the factory, in a clean condition, properly packed and labelled.

All repairs, alterations or replacement of materials or parts not authorised by Metcalfe will automatically void all warranties in their entirety.

All Metcalfe slicers (except Simple Line) and EC20 chipper are covered by a 2-year warranty (1st year parts and labour, 2nd year parts only) and full after sales service.

All Metcalfe MP mixers are covered by a 3-year warranty (1st years parts and labour, 2nd and 3rd year parts only) and full after sales service.

There is a limited 6-month warranty on the following:

- Mixer attachments (beater, whisk and dough hook)
- Chipper blades
- Parts purchased or supplied for the repair of Metcalfe equipment

This warranty does not cover the following:

- Failure due to incorrect installation
- Failure due to neglect, abuse, careless handling or misuse of machine
- Failure caused due to improper maintenance
- Blender clutches
- Knives and gears on can openers
- Sharpening of slicer blades
- General wear and tear

Metcalfe and its suppliers reserve the right to make changes in design and specification to any product without prior notification.

3/2021

Metcalfe Catering Equipment Ltd

Haygarth Park
Blaenau Ffestiniog
Gwynedd, LL41 3PF



 01766 830 456  sales@metcalfecatering.com  www.metcalfecatering.com